

MARQUIS[®] SERIES
.....
FROM TELEMATRIX

INSTALLATION AND USER GUIDE

2800MWD

1 LINE - 10 MEMORY



? Copyright TeleMatrix Inc. 2000





COMPLIANCE AND SAFETY

As specified by FCC regulation, we are required to inform you of specific governmental and compliance regulatory requirements, safety notices, safety instructions and other informative information. TeleMatrix, Inc. provides this information in a separate manual. We pack the separate Compliance and Safety Manual within each outer box or product box when shipped.

Prior to reading this operation manual and prior to setting up your telephone, please refer to the Compliance and Safety Manual.

If the Compliance and Safety Manual is not immediately available. Please obtain a free copy by calling our Priority Care Department (phone number 1-800-462-9446) or by downloading a copy on our Internet (web site address www.telematrixusa.com).





CONTENTS

Features	1
Controls	2
Switch Settings	4
Installation	5
Wall Mounting	7
Programming Speed Dial Memory	8
Operation	11
Care and Maintenance	13
Service	14
Warranty	15





FEATURES

- ?? One Line
- ?? Convenient Data Port
- ?? 10 Single Button Memory Locations With Secure Programming
- ?? Tone Dialing
- ?? Speaker Key
- ?? Mute Key
- ?? Handset Volume Control
- ?? TouchLite™ Message Waiting Retrieval
- ?? NEON/LED Message Waiting Switch
- ?? Store Key (submerged))
- ?? Storable Flash Function (600 mS) (submerged)
- ?? Storable Pause Function (3.6 seconds) (submerged)
- ?? HI/LOW Ringer Volume Control Switch
- ?? Desk or Wall Mountable
- ?? Fully Modular, Easy To Install

CONTROLS

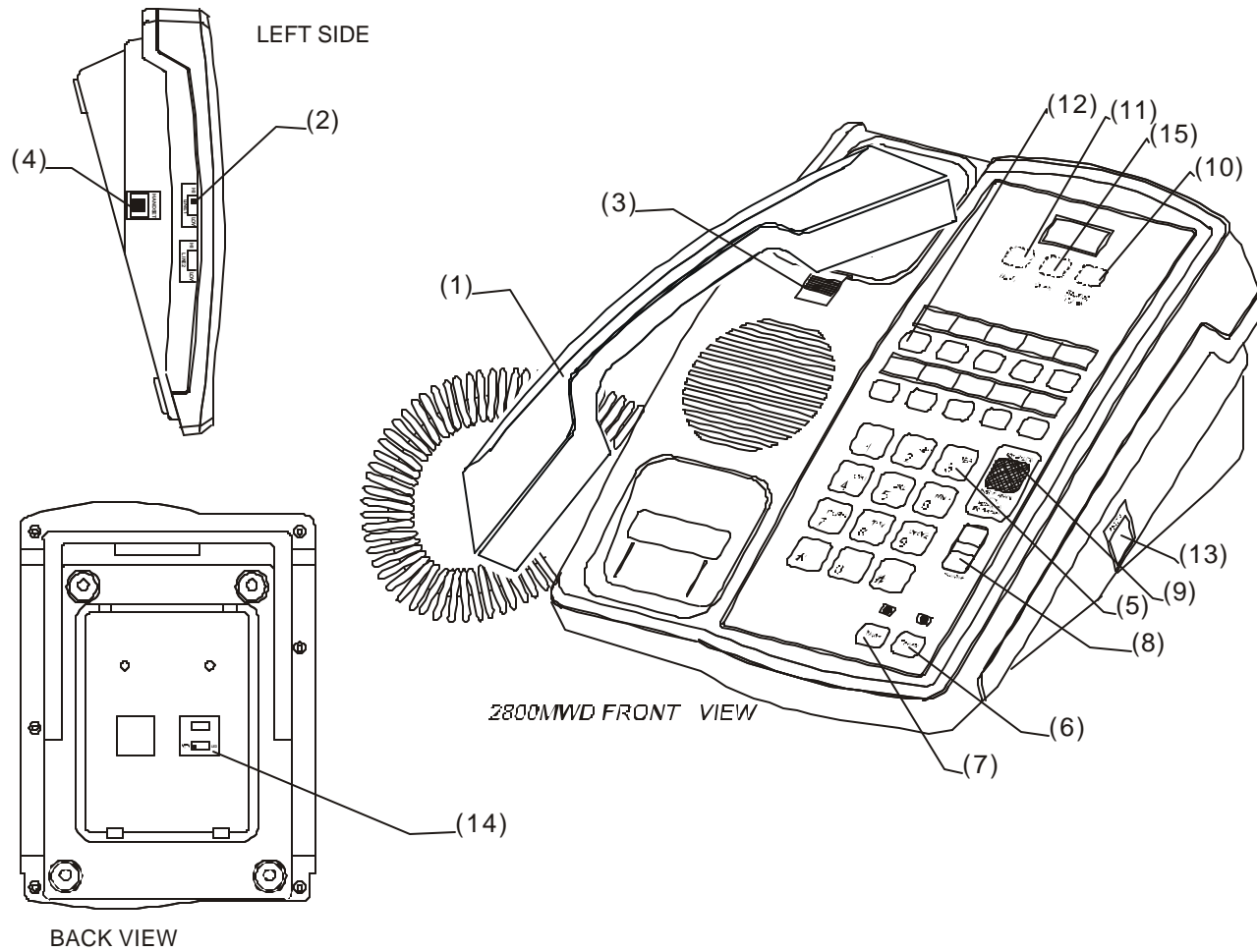

DEFINITION OF CONTROLS

1. Handset Hearing aid compatible, low profile styling.
2. Ringer Controls Adjusts the volume of the ringers to HI/LOW setting.
3. Handset Clip Retains the handset when the phone is wall mounted.
4. Handset Jack Modular receptacle where handset cord plugs into the base unit.
5. Dial Pad Large keys used for dialing.
6. Speaker Key Used to activate speaker
7. Mute Key Used to mute speaker key and handset
8. Handset Volume Control Controls the loudness of the receiver volume when pressed.
9. Message Waiting TouchLite™ Key Used to call voice mail to retrieve messages.
10. Pause Key (Submerged Key) Used to program a 3.6 second pause in memory.
11. Flash Key (Submerged Key) Used to provide a 600 mS line break to access PBX/Centrex.
12. Feature Access Keys 10 Programmable memory locations for frequently dialed phone numbers and access codes.
13. Data Port Used to connect a computer modem, fax machine, or answering device.
14. Message Waiting Selector Switch Select optional 90VDC or Low voltage LED Message Waiting.
15. Store Key (Submerged Key) Used to program information for speed dialing.

SWITCH SETTINGS

There are installer selectable switches located on the bottom base underneath a protective plastic overlay. These switches are hidden behind a plastic cover for security. To locate, remove the plastic covers using a sharp pointer or paper clip as shown.

Message Waiting Selector

The 2800MWD can support 90VDC neon or low-voltage LED message waiting systems. Simply slide the switch to the desired position that is compatible with your PBX messaging system.

Note: the phone is factory preset to the "Neon" setting.

Figure 5

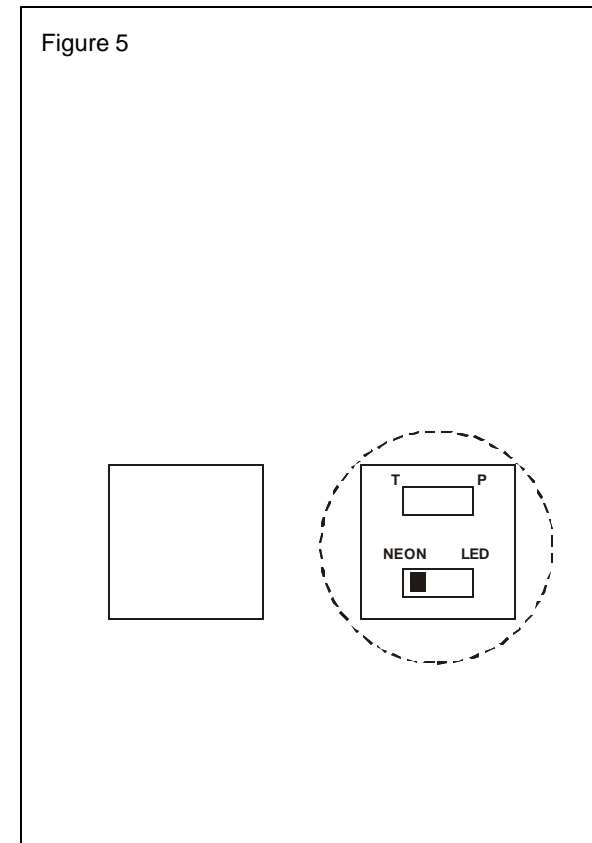

INSTALLATION

Parts Check List

The following parts are included in this package:

1. 15' modular telephone line cord.
2. Modular coiled handset cord.
3. Base unit
4. Handset

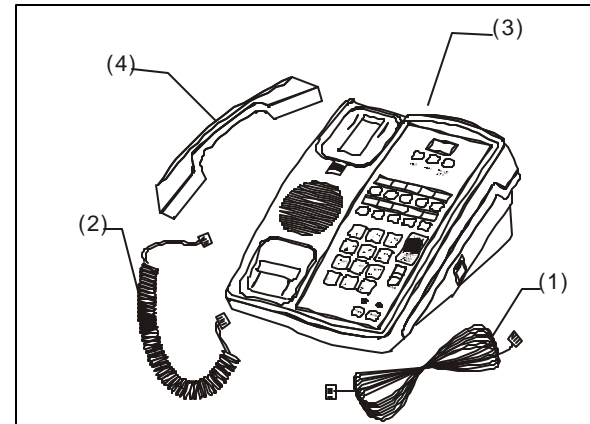

Caution

- ?? Never install telephone wiring during a lightning storm.
- ?? Never install telephone jacks in wet locations unless the jack is specifically designed for wet locations.
- ?? Never touch uninstalled telephone wires or terminals unless the telephone line has been disconnected at the network interface.
- ?? Use caution when installing or modifying telephone lines.

The wall mount wedge is not included. Call the TeleMatrix Priority Care Department for a wall mount wedge.

INSTALLATION

Connecting The Handset Cord

A 10' modular coil handset cord is provided. To install, simply plug one end of the handset cord into the modular jack on the handset. The remaining end of the handset cord plugs into the jack labeled "Handset" located on the left side of the base unit. (figure 3)

Figure 3

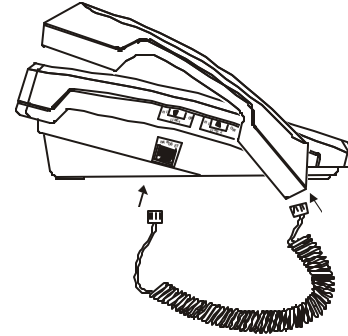

Connecting The Line Cord

A 15' modular line cord is provided. To install, simply plug one end of the line cord into the modular jack located on the back of the base unit. The remaining end of the line cord plugs into the wall jack. (figure 4)

Figure 4

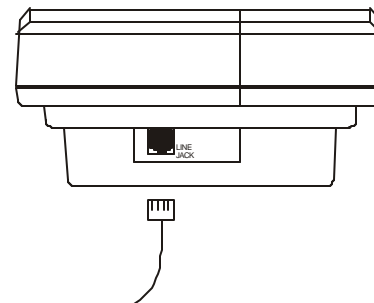

WALL MOUNTING

Wall Mounting Your 2800MWD

The 2800MWD was designed to be conveniently wall mounted. There is no additional hardware required. Follow these easy steps:

1. The handset retaining clip must be engaged to secure the handset when hanging up. To engage the clip, unsnap the clip, rotate the clip 180° and then snap the clip into place. (figure 7)
2. Plug one end of a short line cord (not included) into the line jack on the back of the Marquis base unit. Plug the remaining end of the short line cord into the wall jack. Next, guide the phone onto the studs of the wall jack. Pull down firmly until you feel it snap into place. The unit is now wall mounted. (figure 8)

1. ↑ UNSNAP
2. ↻ ROTATE 180°.
3. ↓ SNAP INTO PLACE.

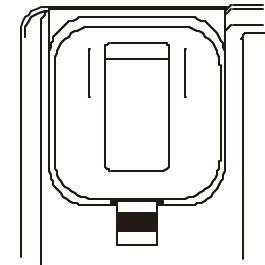
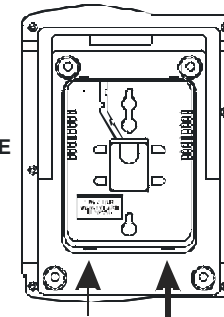

Figure 7

Figure 8

- MOUNTING WEDGE**
1. PRESS THE RELEASE TABS.
 2. SNAP INTO PLACE.



PROGRAMMING SPEED DIAL

A. The “STORE”, “FLASH”, and “PAUSE” function keys are located underneath the clear plastic overlay and paper faceplate. To access, lift off the overlay and paper faceplate using a paperclip or sharp pointer. (figure 9 and 10)

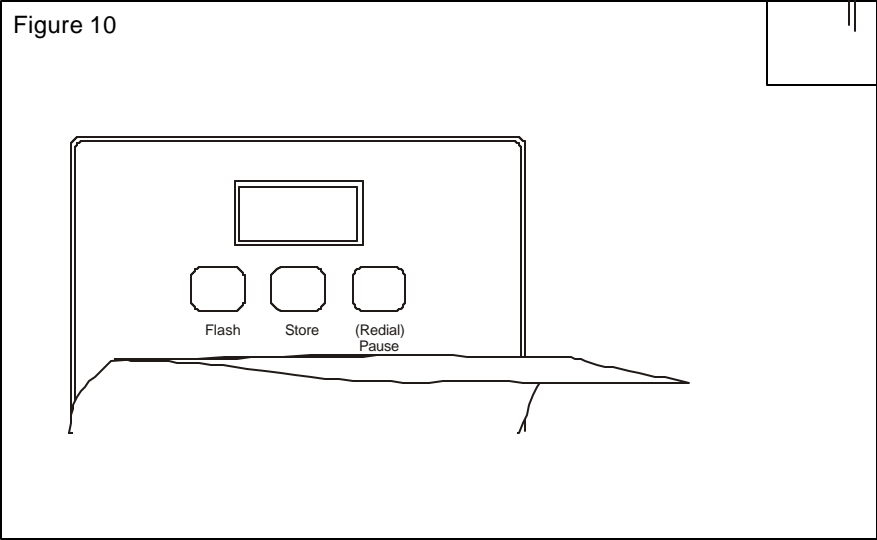
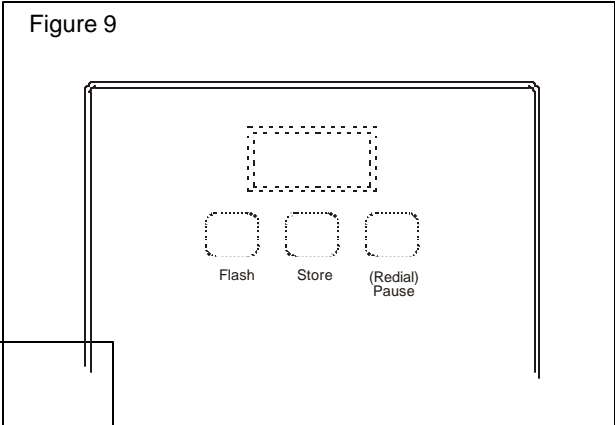

PROGRAMMING SPEED DIAL

B. Storing A Number Into Memory

Up to 10 phone numbers can be stored into memory. Each location can store up to 15 digits in tone mode and 16 digits in pulse mode.

Note: a "PAUSE" or "FLASH" programmed into memory counts as one digit when storing a number.

1. Check the position of the tone/pulse switch.
2. Lift the handset.
3. Press the STORE key.
4. Enter the numbers to be stored using the numeric dial pad.
5. Press the desired memory location wherein the number is to be stored.
6. If additional numbers are to be stored, repeat steps 4 thru 6.
7. Hang up the handset.

C. Storing "PAUSE" Into Memory

If you are using your 2800MWD anywhere that requires an access code for outside calls, you may need to add a "PAUSE" to the number to allow time for the outside line to connect. You can enter as many pauses as needed.

Note: a "PAUSE" or "FLASH" programmed into memory counts as one digit when storing a number.

1. Check the position of the tone/pulse switch.
2. Lift the handset.
3. Press the STORE key.
4. Enter the required access code using the numeric dial pad.
5. Press the "PAUSE" key.
6. Enter the digits to be stored using the numeric dial pad.
7. Press the desired memory location wherein the number is to be stored.
8. If additional numbers are to be stored, repeat steps 4 thru 6.
9. Hang up the handset.

D. FLASH Hook Function

The Flash function is used to access PBX features or Telco line features such as Call Waiting. The FLASH function is a 600mS timed line beak. If the FLASH function will be used often, store the feature into memory location for easy access as follows:

1. Check the position of the tone/pulse switch.
2. Lift the handset.
3. Press the "FLASH" key.
4. Press the memory location wherein the "FLASH" is to be stored.



PROGRAMMING THE *TouchLite*™

FEATURE DESCRIPTION

TouchLite™ is a new innovation that integrated the visual message waiting lamp and a speed dial key into one. It allows easy access for guests to retrieve messages.

When the message waiting lamp lights to notify the guest that a message is waiting, a simple press of the RED TouchLite™ connect the guest to the message center or front desk.

TouchLite™ also adds an additional memory location to this telephone. (6 to 11 total speed dial memories depending on the model)

PROGRAMMING TouchLite™

1. Check the position of the tone/pulse switch.
2. Lift the handset.
3. Press the "STORE" key.
4. Enter the numbers to be stored using the numeric dial pad.
5. Press the red TouchLite™ key to store.
6. Hang up the handset.
(figure 9 and 10)



OPERATION

PLACING A CALL USING THE HANDSET

- ?? Lift the handset.
- ?? Dial out by using the numeric dial pad or by pressing a speed dial location.

RECEIVING A CALL USING THE HANDSET

- ?? lift the handset when ringing.

HANDSET VOLUME CONTROL

The handset volume control increases the volume of the handset.

When the handset is off hook, press the volume control key to increase the headset volume. The volume control is a HI/LOW operation and is hearing aid compatible.

OPERATION

Placing A Call Using The Speakerphone

The 2800MWD is equipped with a high quality speakerphone feature to allow for hands free operation.

To use, simply press the “Speaker On/Off” key when placing or answering a call. The telephone line will activate automatically. The “Speaker” key will light up indicating that the speakerphone is in-use. To hang-up, press the “Speaker On/Off” key again.

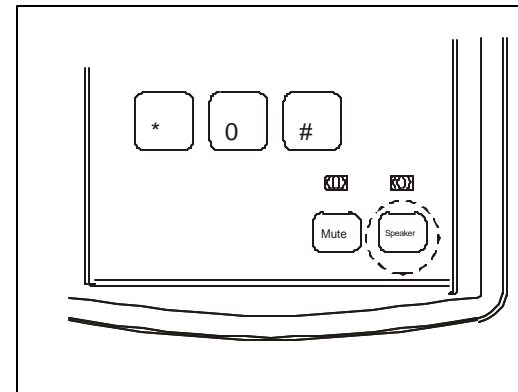

Using The Mute Feature

A “Mute” key is provided to allow privacy during a background conversation. When the “Mute” key is activated, the microphones in the handset and the speakerphone are disabled. When the “Mute” feature is activated, the caller will not hear your voice. The “Mute” key will light to show that the feature is activated. To de-activate, press the “Mute” key again.

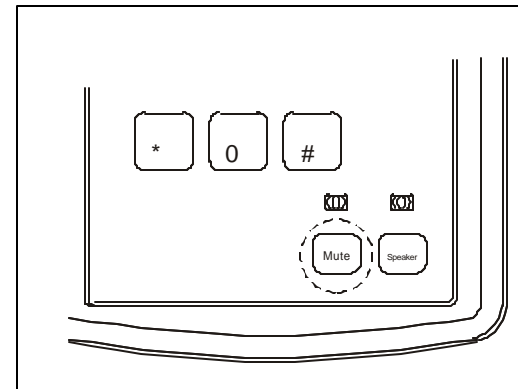

CARE AND MAINTENANCE



Keep the telephone dry. If it gets wet, wipe it dry immediately. Liquids might contain minerals that can corrode the electronic circuits.



Use and store the telephone only in normal temperature environments. Temperature extremes can shorten the life of electronic devices, damage batteries, and distort or melt plastic parts.



Keep the telephone away from excessive dust and dirt that can cause premature wear of parts.



Wipe the telephone with a damp cloth occasionally to keep it looking new. Do not use harsh chemicals, cleaning solvents, or strong detergents to clean the system.



SERVICE

When problems arise during installation or service that cannot be resolved using this or related documents, contact the TeleMatrix Technical Service department 8:30a.m. - 4:30p.m. MST:

Toll Free: 1-800-462-9446
Direct: 719-638-8821
Fax: 719-638-8815
www.telematrixusa.com

Many times a problem is either installation or user related. Please contact TeleMatrix PRIOR to sending a telephone to our service center for repair. In the unlikely event that a factory repair be necessary:

1. Include a brief description of the trouble that you are experiencing.
2. Include a proof of purchase for a repair under warranty.
3. Send the telephone prepaid by UPS or Parcel Post insured to:

TeleMatrix, Inc.
Customer Care Center
5025 Galley Road
Colorado Springs, CO. 80915

TeleMatrix will pay to return the repaired telephone to you. Allow 2-3 weeks for delivery.

WARRANTY

STATEMENT OF LIMITED WARRANTY

TeleMatrix, Inc. and TeleMatrix Equipment, LLC (TMX) warrants to its [original end customer] [purchaser] that Spectrum, Spectrum Plus and Marquis branded products manufactured by TMX are free from defects in materials and workmanship for five (5) years after the date of purchase, and Regency branded products manufactured by TMX are free from defects in materials and workmanship for three (3) years, other than the following products for which the warranty period shall be one (1) year: handset batteries, either NiCd or NiMH, used in TMX cordless products. If a product fails this warranty during the warranty period, TMX will, at its option, either repair or replace the defective product or parts, or deliver replacements for defective products or parts on an exchange basis at no additional charge to the customer except as set forth below. Repair parts or replacement products may be either new or reconditioned. Products or parts returned to TMX under this warranty will become the property of TMX. Warranties on products repaired by TMX expire at the termination of the original warranty period.

This limited warranty does not cover:

1. Products or parts which are damaged, abused or misused;
2. Any damage resulting from improper installation, maintenance or operation of the product;
3. Damage resulting from unauthorized modification or repair of the product, or from improper connection of the product to other equipment;
4. Cords, connectors and replaceable batteries;
5. Damage in transit to the TMX repair facility;
6. Any product or part unless proof of date of purchase is submitted with the product when returned for warranty repair; or
7. Costs incurred by the customer in removing and shipping the product to TMX for repair or replacement, and costs of reinstallation of the product.
8. Products or parts which are not owned and used by the original end user customer.

The cost and risk of loss or damage for sending the product to TMX will be borne by the customer.

TMX EXPRESSLY DISCLAIMS ALL WARRANTIES EXCEPT THE LIMITED WARRANTY SET FORTH HEREIN, WHICH IS THE SOLE AND EXCLUSIVE WARRANTY OF THE PRODUCT, AND IS IN LIEU OF ALL OTHER WARRANTIES, WHETHER ORAL OR WRITTEN, EXPRESS OR IMPLIED, OR STATUTORY. THERE ARE NO IMPLIED WARRANTIES OF MERCHANTABILITY OR FITNESS FOR A PARTICULAR PURPOSE. THE CUSTOMER'S SOLE REMEDY UNDER THE TMX WARRANTY SHALL BE REPAIR OR REPLACEMENT AS PROVIDED ABOVE. IN NO EVENT WILL TMX BE LIABLE TO CUSTOMER OR ANY OTHER PARTY FOR ANY INDIRECT, INCIDENTAL OR CONSEQUENTIAL DAMAGES, INCLUDING, WITHOUT LIMITATION, DAMAGES OF LOST PROFITS, LOST REVENUES, LOSS OF USE OF FACILITIES OR EQUIPMENT, OR COST OF SUBSTITUTE EQUIPMENT ARISING OUT OF THE USE OR INABILITY TO USE THIS PRODUCT, EVEN IF THE CUSTOMER HAS ADVISED TMX OF THE POSSIBILITY OF SUCH DAMAGES. TMX LIABILITY FOR DAMAGES SHALL NOT EXCEED THE PURCHASE PRICE OF THE DEFECTIVE PRODUCT.

This limited warranty is non-transferable without the prior written approval of TMX. It gives the customer specific legal rights. The customer may have other rights which vary under local law. Some jurisdictions may not allow limitations on the term of an implied warranty or exclusions or limitations of incidental or consequential damages.

This page was intentionally left blank.

252-0266 (2800MWD)
Revision May 1, 2003